

m o o o i

Pallana Light 6

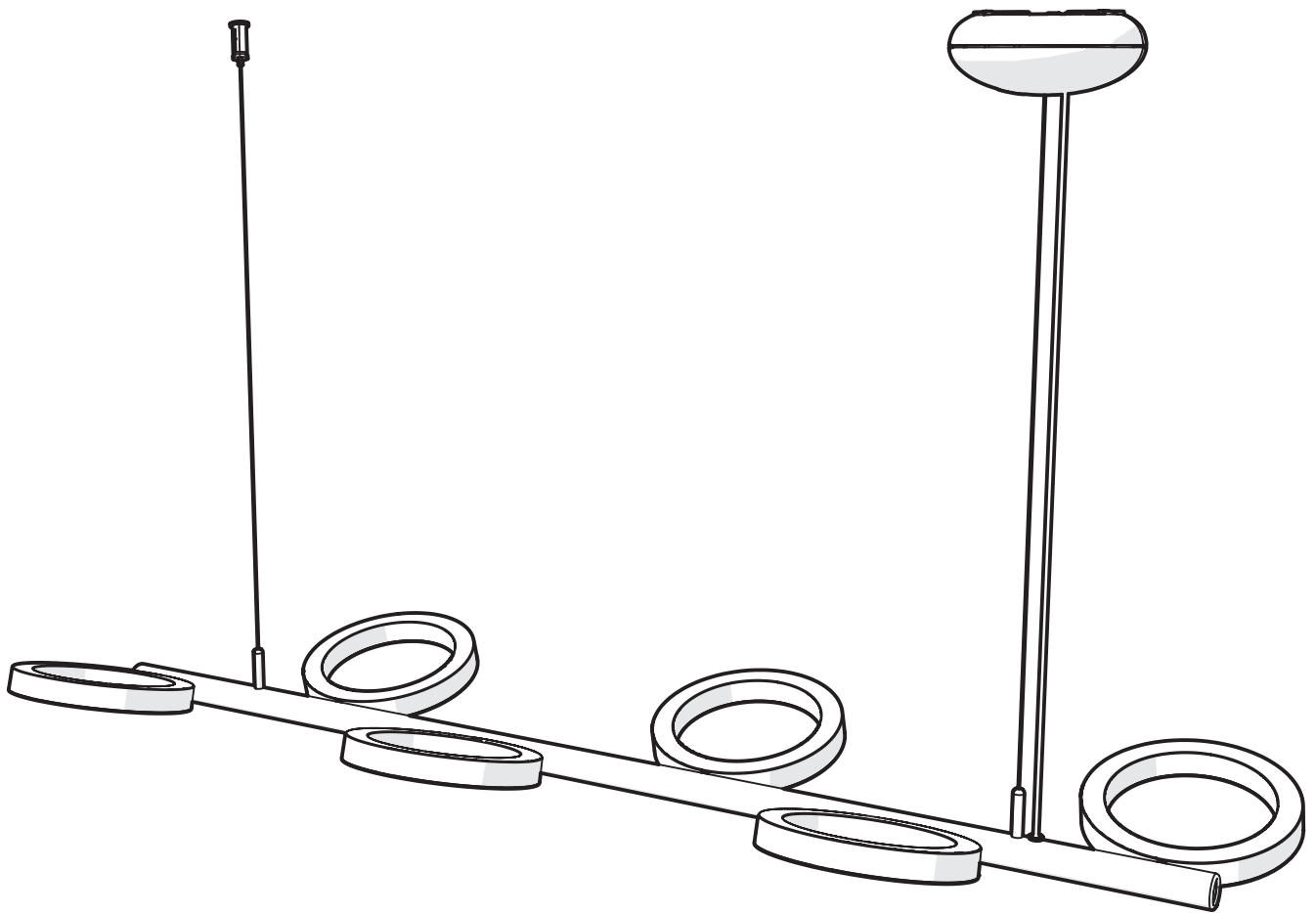

visit www.moovi.com for more information about the collection

m o o o i

Pallana Light 6

i



PLEASE HANDLE THIS PRODUCT WITH CARE. NEVER PLACE THE LAMP ON THE GROUND. THIS MAY DAMAGE THE PRODUCT.

请小心使用本产品. 切勿将灯放在地面上. 这可能会损坏产品.

NOT INCLUDED
不包含

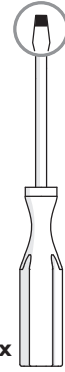
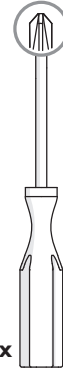
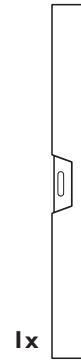
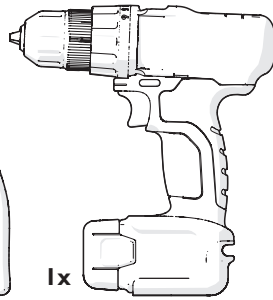
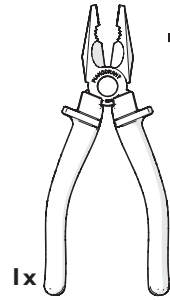

INCLUDED
包括

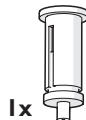

THE LIGHT SOURCE CONTAINED IN THIS LUMINAIRE SHALL ONLY BE REPLACED BY THE MANUFACTURER OR HIS SERVICE AGENT OR A SIMILAR QUALIFIED PERSON.

此灯具内的光源应由制造商或其服务代理商或类似的有资格人员来更换。

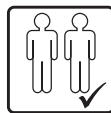

IF THE EXTERNAL FLEXIBLE CABLE OR CORD OF THIS LUMINAIRE IS DAMAGED, IT MUST BE REPLACED BY THE MANUFACTURER, ITS SERVICE AGENT, OR A SIMILARLY QUALIFIED PERSON TO AVOID HAZARDS.

如果此灯具的外部软缆或软线损坏了, 该线要由制造商或其他服务代理商或有类似资格的人更换, 以避免发生危险。

THE INSULATION BETWEEN THE LOW VOLTAGE POWER SUPPLY AND THE CONTROL CONDUCTOR IS BASIC INSULATION LV.

电源与控制导体之间的绝缘类别为基本绝缘。

m o o o i

Pallana Light 6

1

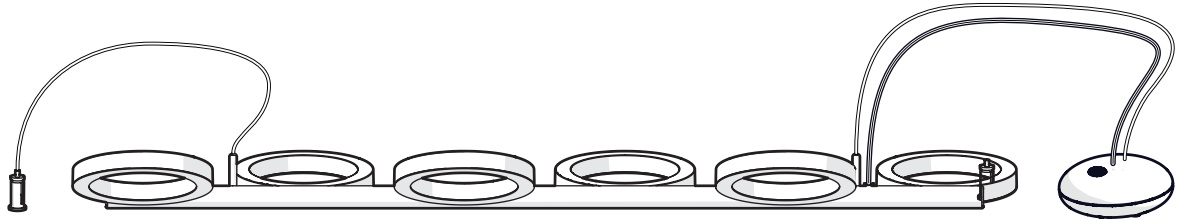

2

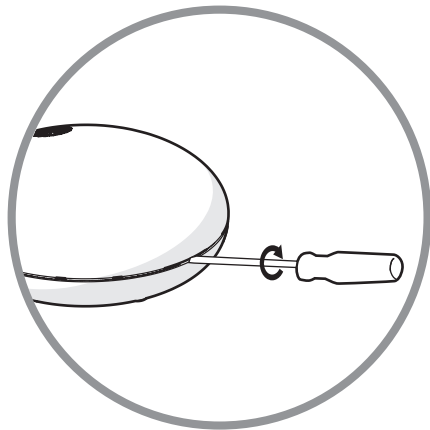

m o o o i

Pallana Light 6

3

1

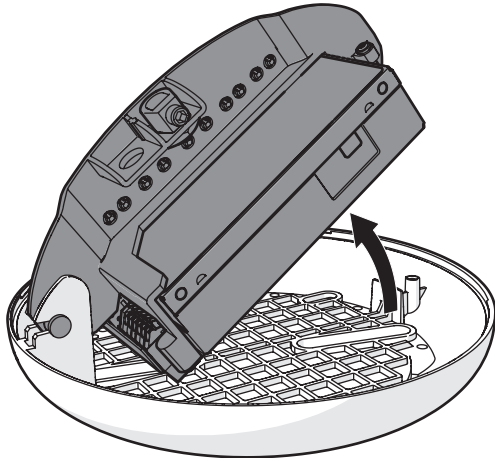

2

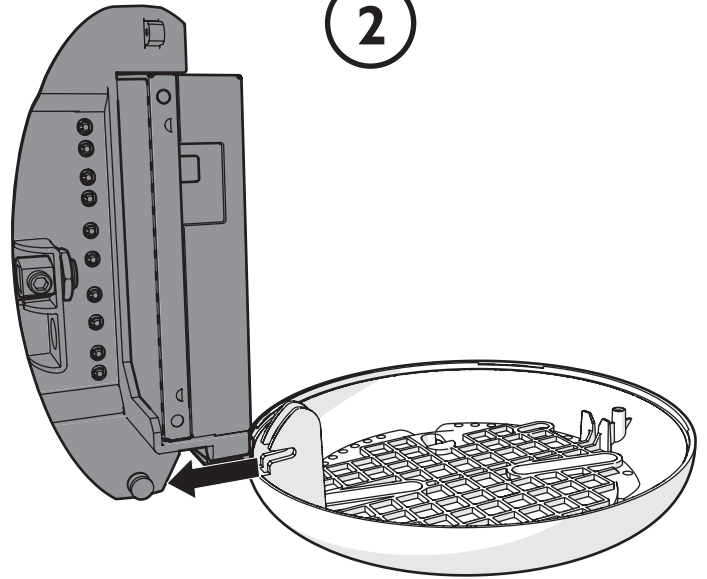

4

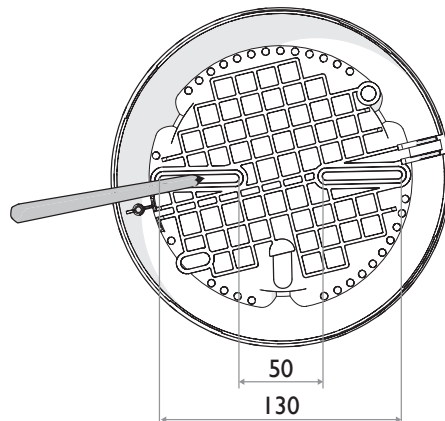
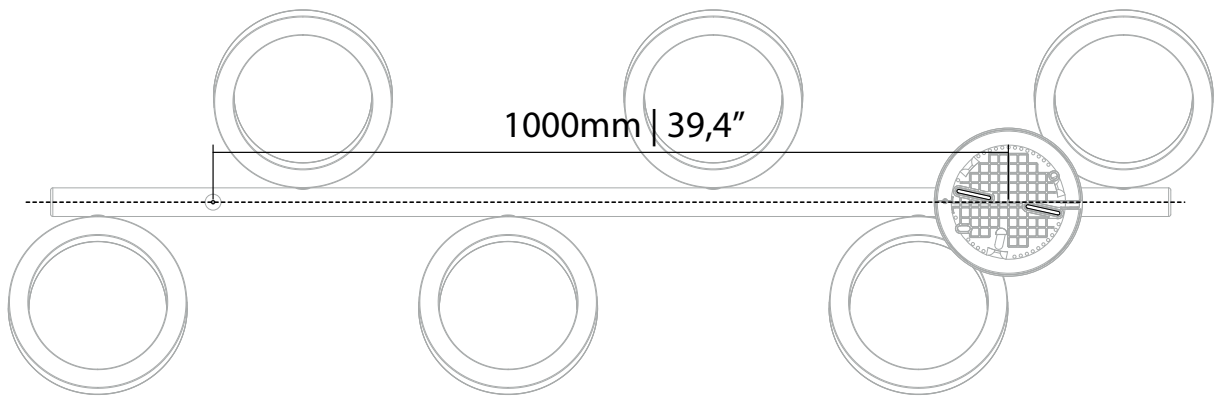

visit www.mooui.com for more information about the collection

m o o o i

Pallana Light 6

5

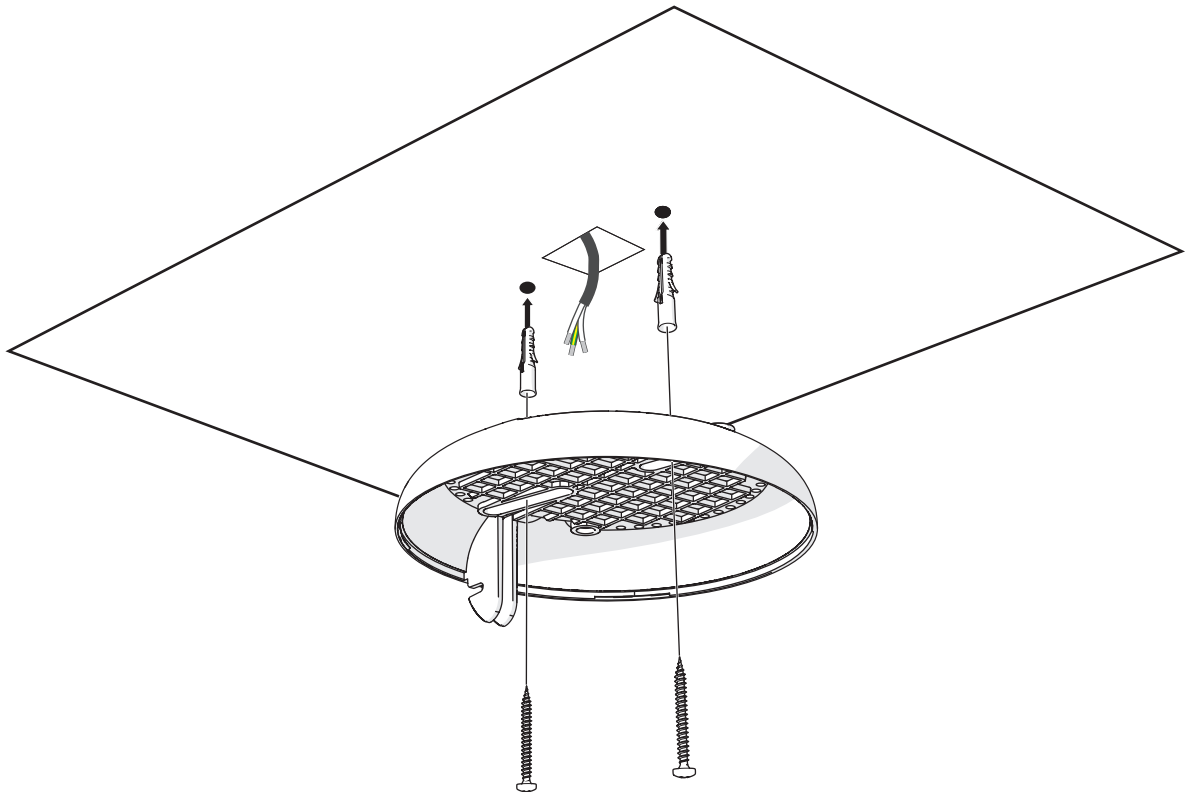

6

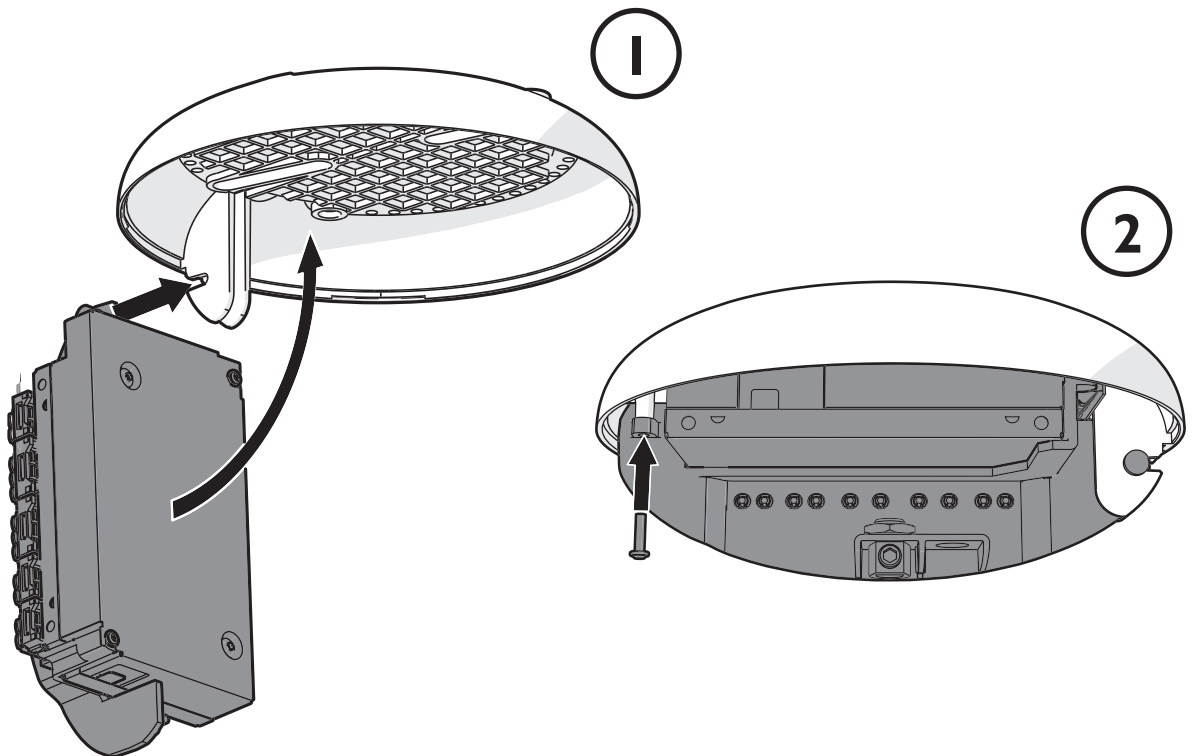

visit www.moovi.com for more information about the collection

m o o o i

Pallana Light 6

7

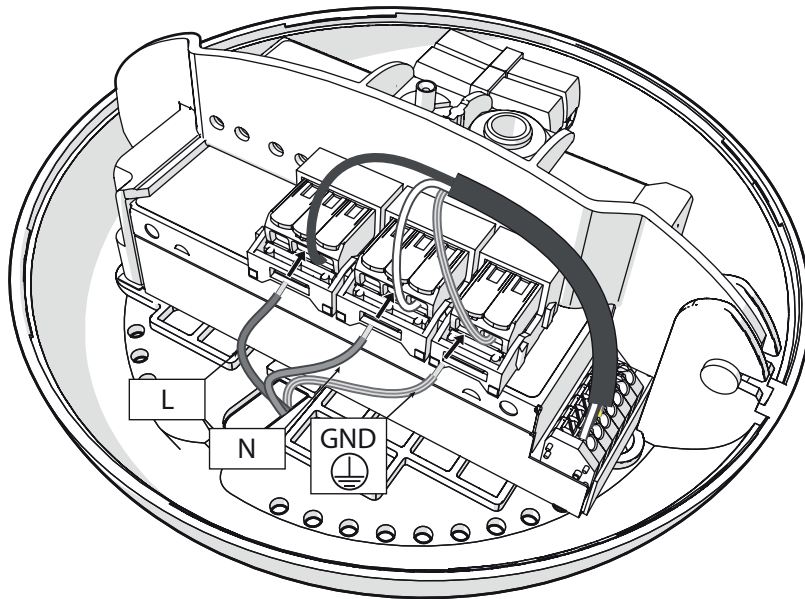

8

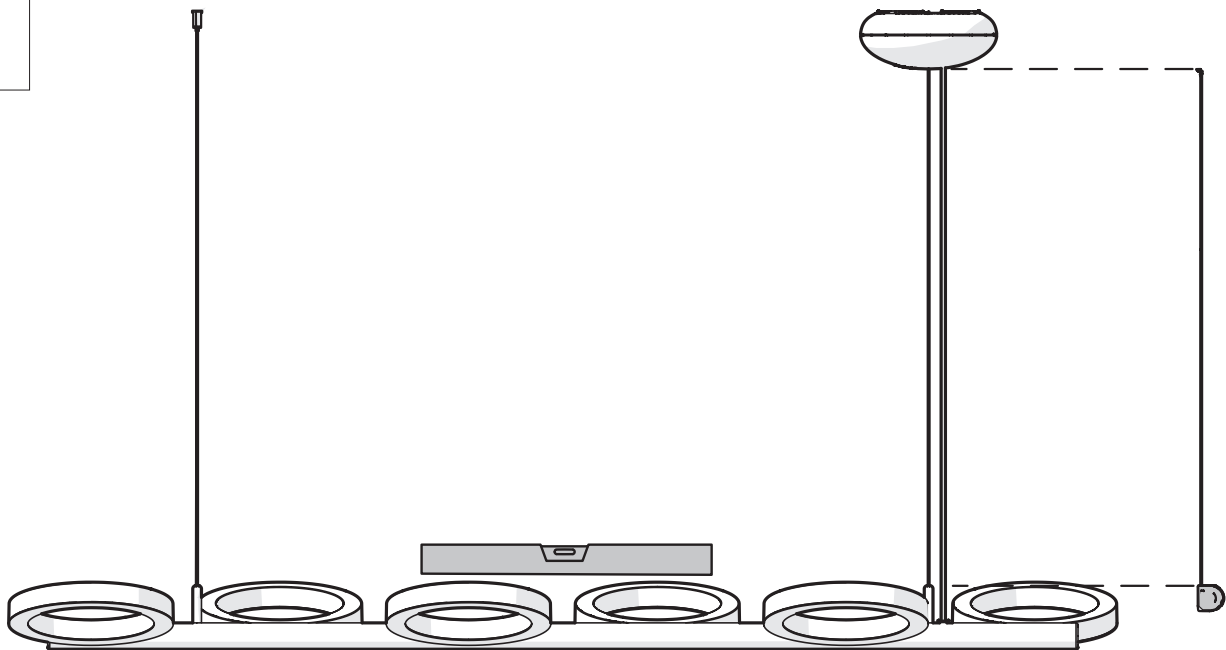

m o o o i

Pallana Light 6

9

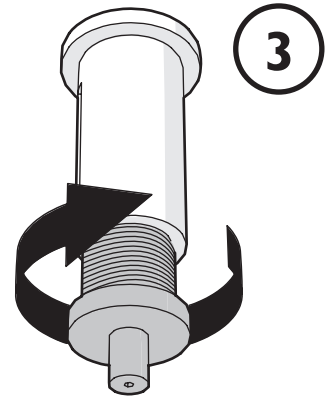
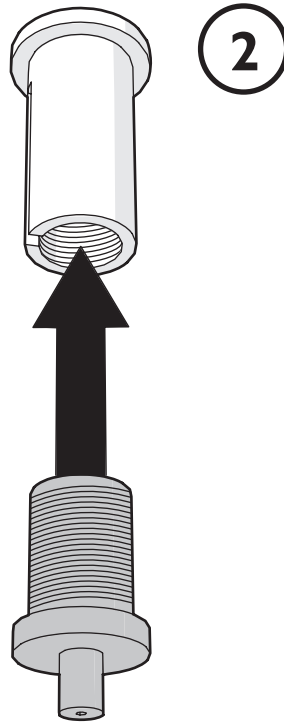
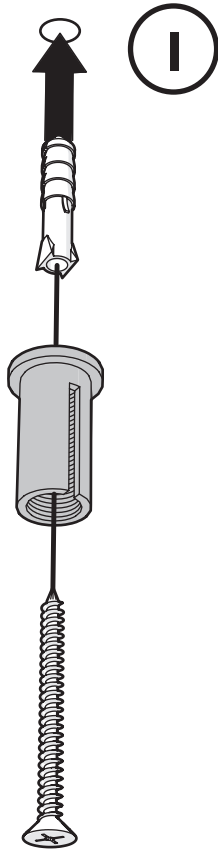

10

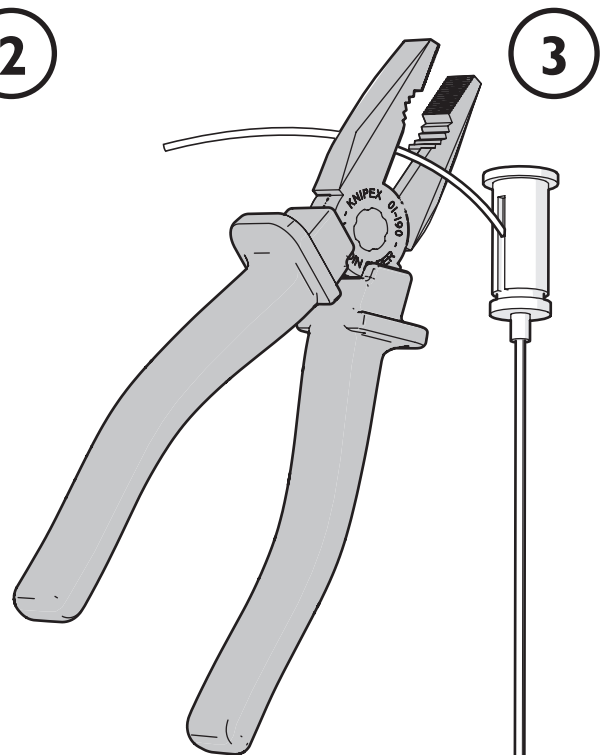
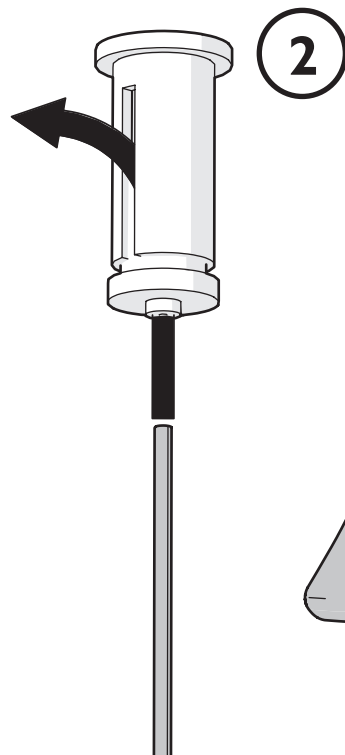
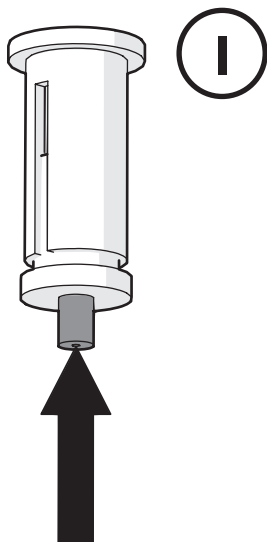

visit www.moovi.com for more information about the collection

moooi

Pallana Light 6

II

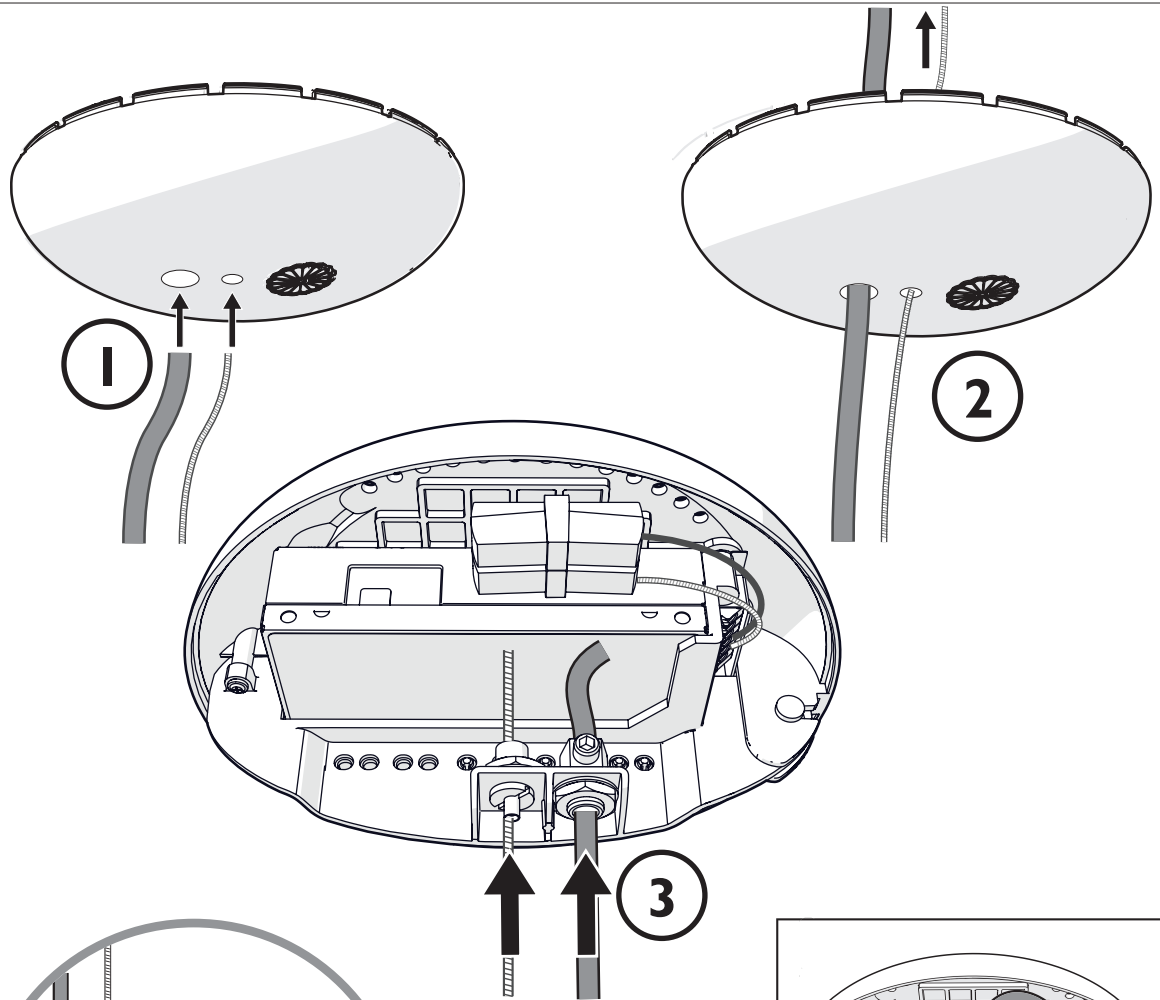

12

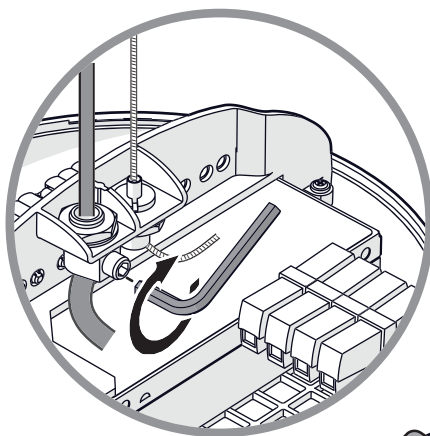

1

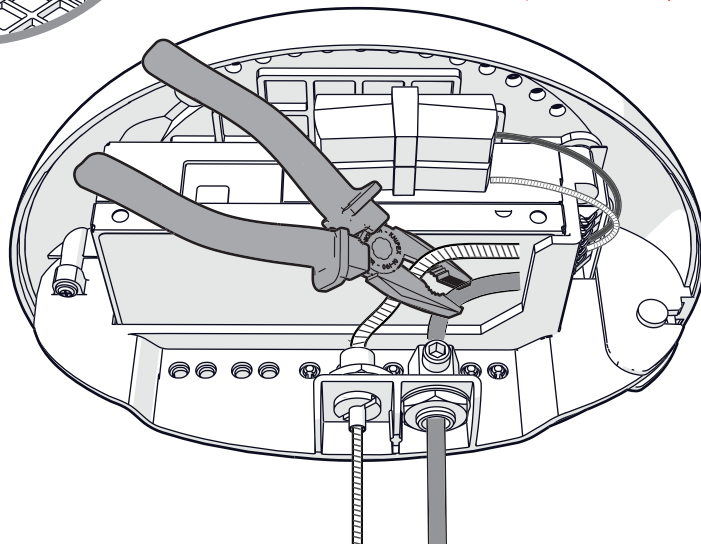
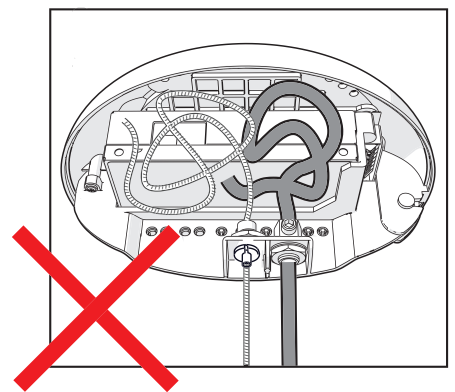

2





visit www.moooi.com for more information about the collection

m o o o i

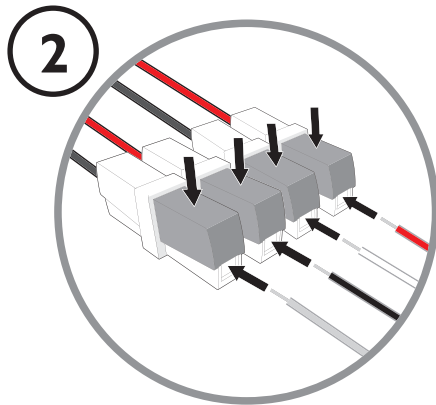
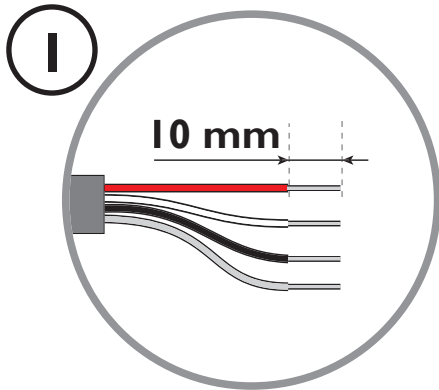
Pallana Light 6

13



-  Transparent cable with white line
-  Transparent cable with black line
-  Transparent cable with red line
-  Transparent cable without colored line

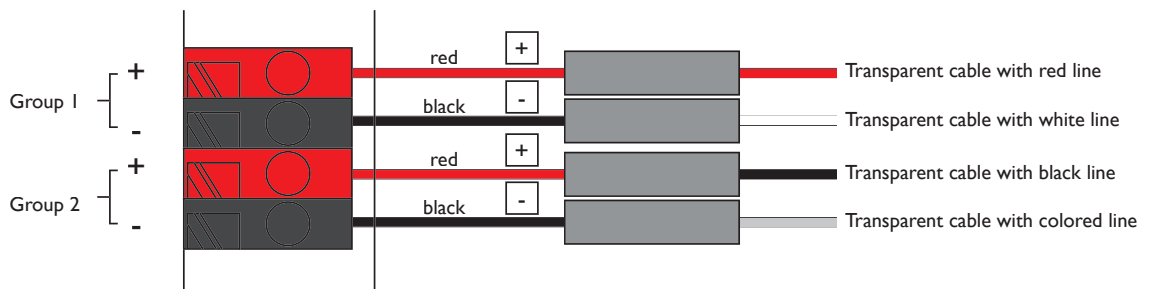
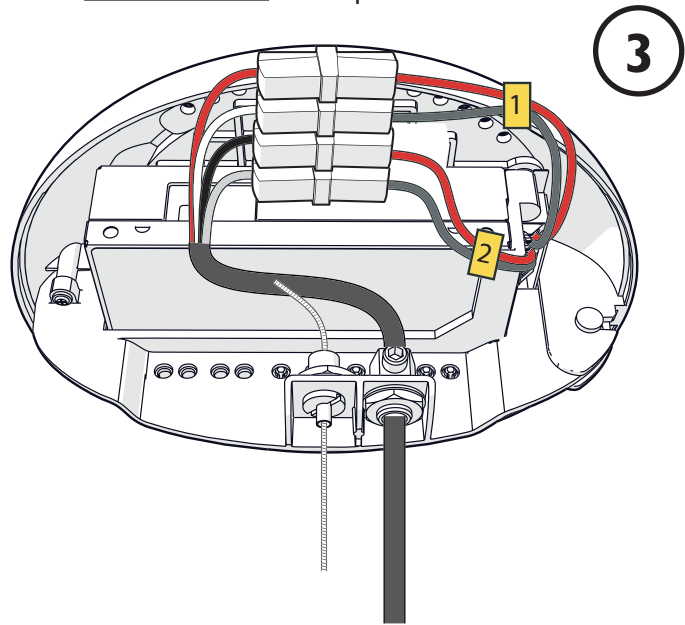

m o o o i

Pallana Light 6

14

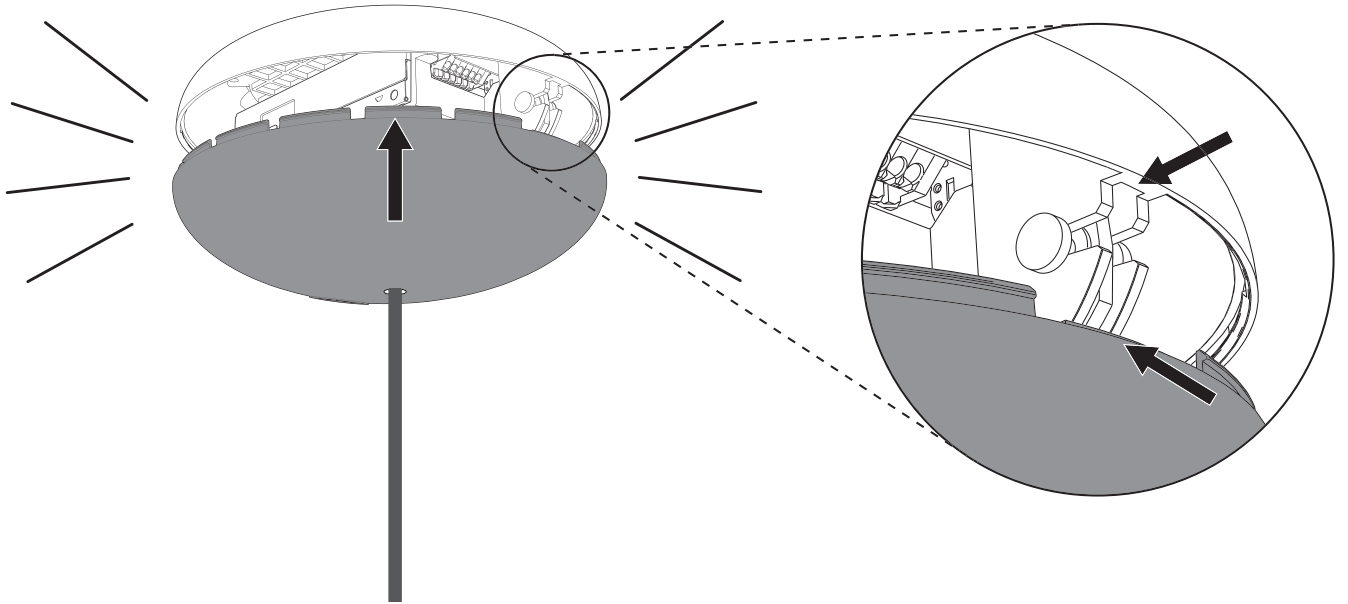

i

① WWW.MOOOI.COM/
THE-BUTTON

② SCAN AND REGISTER
扫描并注册

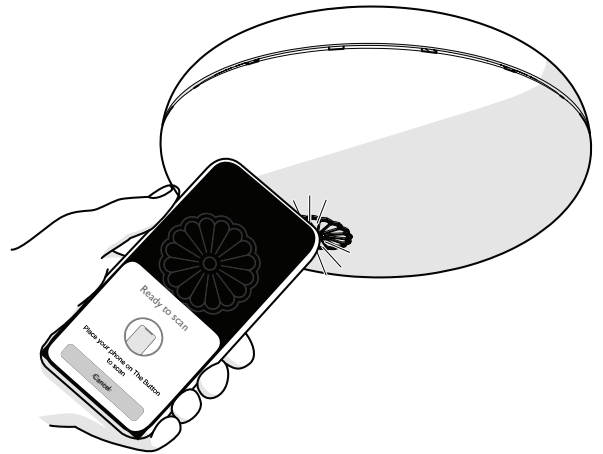
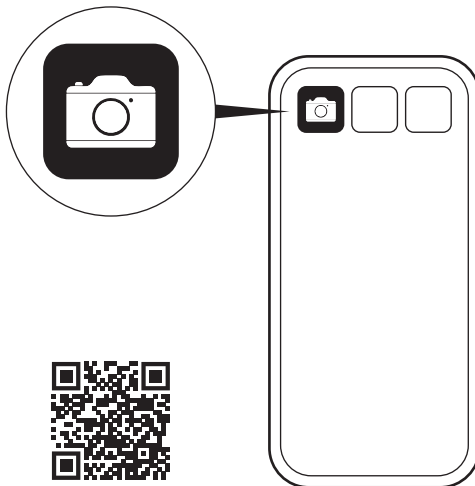

visit www.moooi.com for more information about the collection

m o o o i

Pallana Light 6

i

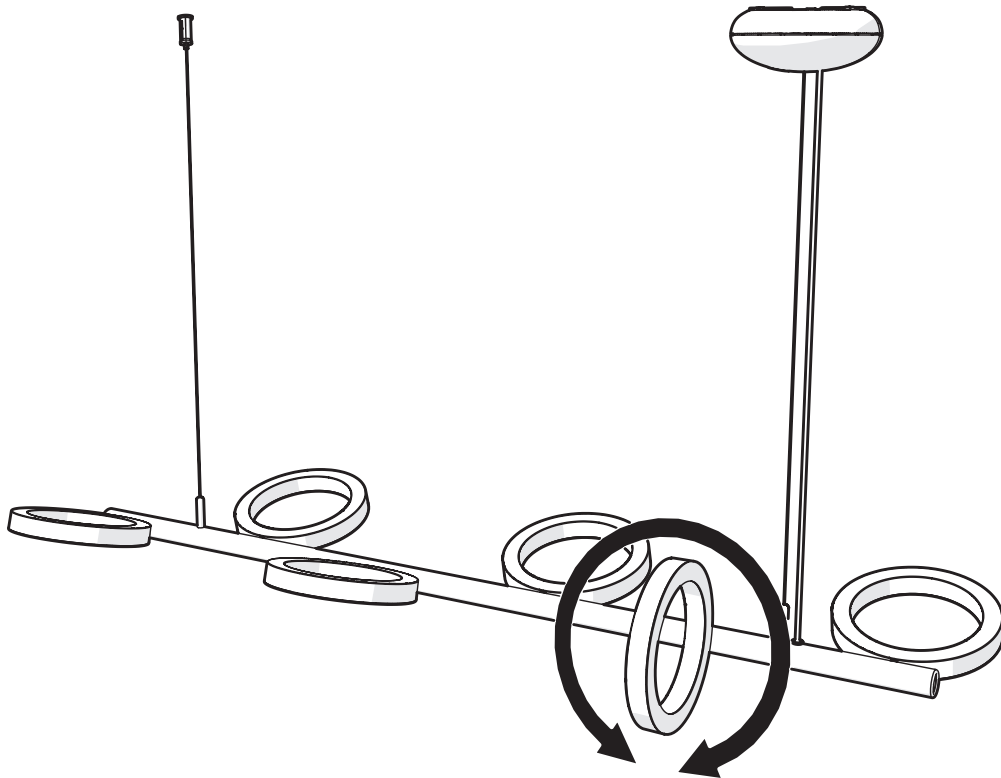

i

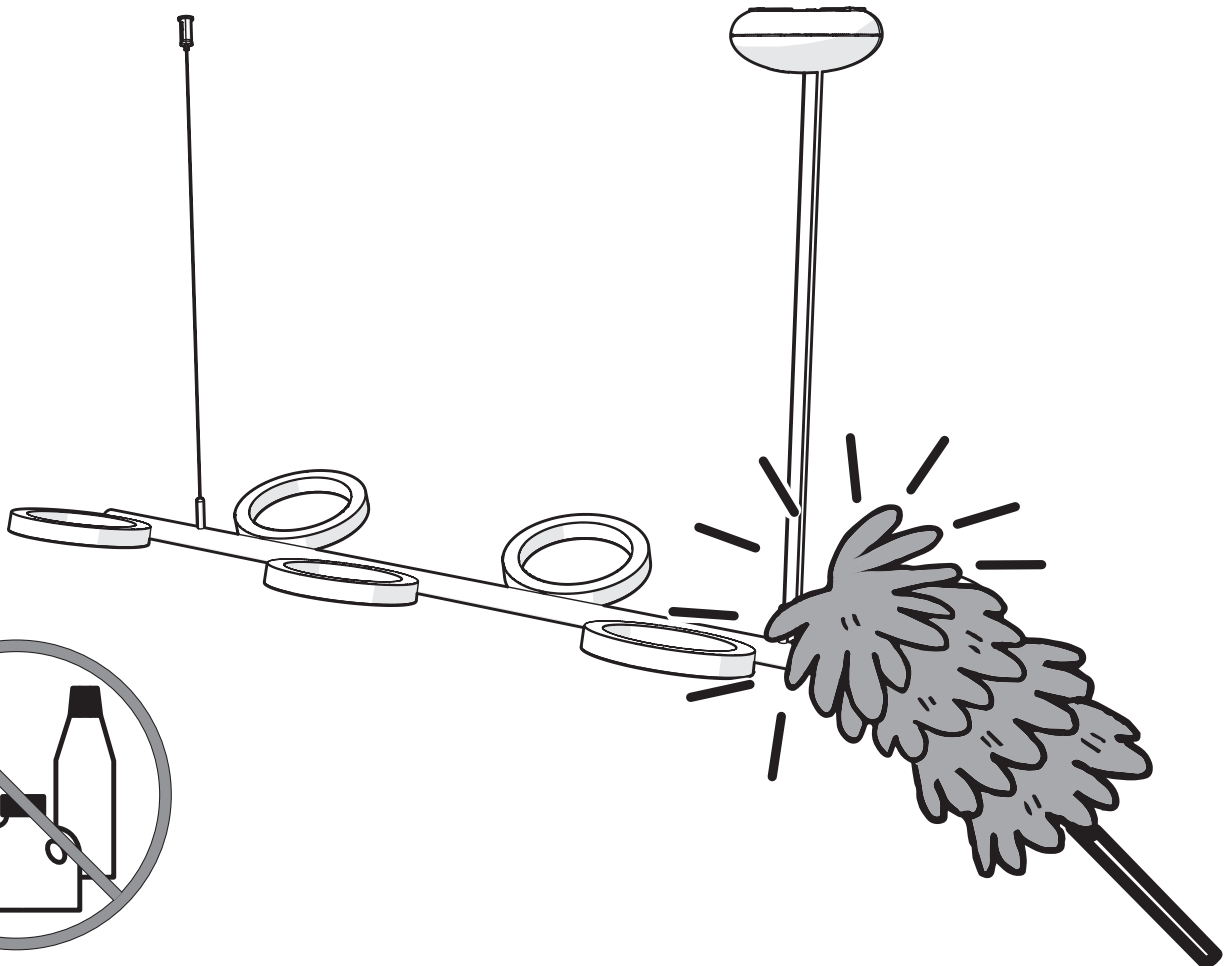

visit www.mooui.com for more information about the collection

m o o o i

Pallana Light 6

Thank you!
谢谢!

Ceiling Canopy (Pebble III)



WIDTH 18,5cm | 7.28"
HEIGHT 8cm | 3.15"
DEPTH 18,5cm | 7.28"
DIAMETER 18,5cm | 7.28"
MATERIAL Polycarbonate 5VA
DRIVER EldoLED Solodrive SL0560
INPUT VOLTAGE 120 - 250V
INPUT FREQUENCY 50/60Hz
OUTPUT POWER 50W MAX
OUTPUT CURRENT Constant current, programmed
DATASHEET Visit EldoLED.com for full driver datasheet

DIMMING & LIGHTING CONTROL

Wireless Wall Switch

With our Wireless Wall Switch, you'll have full control over your Moooi lighting design with one touch. Our Wireless Wall Switch comprises two components, a wall switch and radio device to put in the canopy of your Moooi lighting design. The wall switch can be integrated in System 55 or Decora style wall switches. The Wireless Wall Switch communicates via Bluetooth with the radio device in the luminaires canopy. Within moments you can enjoy full and fluent dimming, all the way to dark.

The Wireless Wall Switch and radio devices are sold separately via moooi.com, our shops and dealers.

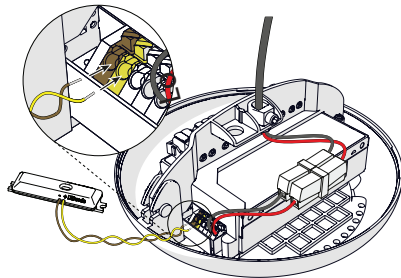

Mains / ELV dimming is not possible.

The Wireless Wall Switch is advised in this case.



WARNING! ONLY USE THIS PEBBLE III FOR THE PRODUCT STATED ON THE LABEL INSIDE.



WARNING! RISK OF ELECTRICAL SHOCK.



DISCONNECT POWER BEFORE WIRING.



MAKE SURE THE DIMMER AND DRIVER ARE COMPATIBLE.

DALI dt6

The luminaire is dimmable by integrating it into a DALI network. This is an universal and professional standard in home automation systems with endless control possibilities and ease. We advise to hire a professional to integrate the luminaire into your DALI network. DALI dt6 can also be used for commercially available converters, enabling the product to be integrated in 3rd party smart home systems.

